

Service Bulletin 28



1. General

(a) Service Bulletin No:	28
(b) Revision / Date	2 / 04-March-2020
(c) Title:	Stratus Double Burner, Burner Hanger Inspection
(d) Description:	Inspection / Replacement of Stratus Double Burner Hanger.
(e) Applicability:	<p>Manufacturers: Altisph'air, Ballons Libert sprl, Ballonservice & Technik, Balóny Kubíček spol. s.r.o., Ballons Chaize, Cameron Balloons Ltd., Lindstrand Hot Air Balloons Ltd., Lindstrand Technologies, Llopis Balloons, Notheisz HAB, Nouvelle Manufacture d'Aerostats, Schroeder Fire Balloons GmbH, Sup-Air, Ultramagic S.A.</p> <p>TCDS Numbers: Austria BA 009-ACG, EASA.BA.003, EASA.BA.010, EASA.BA.012, EASA.BA.013, EASA.BA.014, EASA.BA.015, EASA.BA.016, EASA.BA.019, EASA.BA.021, EASA.BA.022, EASA.BA.025, EASA.BA.026, EASA.BA.030, EASA.BA.119, EASA.BA.517, EAS.IM.BA.110 and France No.186.</p> <p>Burner Assembly Part Numbers: CB8720 & CB8721.</p>
(f) Effectivity:	All CN where Stratus Double Burners are used; burner serial number up to & including 320.

Note: Applicability= All types and variants to which the change can be applied.
Effectivity = Actual CN or group of CN's to which the bulletin has been/will be applied.

2. Background:

A Stratus burner hanger, CB8504, has failed in service after landing. The burner hanger failed, leaving one burner unit detached from the load frame. Examination of our records shows a small number of similar failures.

The failures appear to be caused by progressive fatigue cracking of the welded joint between the central tube and the end plate of the hanger assembly

An improved version of the hanger was introduced with CB8504 Issue D in 2009 which is stronger and more easily inspected.

3. Compliance (Category) and times: Required within 30 days or 10 flights.

4. Consequences of Non-Compliance (Possible): Failure of the burner hanger may result in one or both cans detaching from the frame, resulting in an unsafe condition.

5. Required Action (s):

1/ Identify the build standard of the burner hanger - see accomplishment instructions section 2; CBL/TN/DCB/3191 Issue B or later issue.

2/ If the burner hanger is identified to be issue C or earlier inspect the hanger for cracks in the weld - see accomplishment instructions Section 3: CBL/TN/DCB/3191 Issue A or later issue.

3/ Should any visible cracks be found further flight with the affected burner is not permitted. Report any observed defects to technical@cameronballoons.co.uk attaching photographs if available. **Cracked hangers must not be re-welded.** Repair affected burners by replacing the cracked hanger with a new issue D or later burner hanger.

4/ Record the inspection in the aircraft log-book.

5/ For burners with hanger CB8504 issue C or earlier the inspection must be repeated at each annual inspection.

6/ A number of burners were produced in 1995 / 1996 using a doubler plate to reinforce the central part of the hanger bracket (Fig 2). The welded joint is hidden by the doubler plate and therefore impossible to inspect. Hangers of this design must be replaced by a new hanger CB8504-0000 Issue D or later.



Fig 1. Hanger with Weld Crack.



Fig 2. Hanger with doubler plate.

6. **Materials** - See CBL/TN/DCB/3191 Issue A or later

Service Bulletin 28



7. *Other Publications Affected* None

8. **Mass (Weight)/Balance:** Not affected

9. **Maintenance and Operating Instructions** Not affected

10. **Additional Information**

An improved burner hanger, CB8504-0000 Issue D or later is available for retrofit from Cameron Balloons Ltd.

Fitting of the CB8504-0000 Issue D or later constitutes terminating action for the repetitive inspections required by Section 5 paragraph 5 above.

The contents of this bulletin will be added to the Cameron Balloons Inspection Schedule at its next revision (Maintenance manual Section 6).

Compiled by:

DC Boxall



Notes:

Date: *04-03-20*

Name:

11. **Design Organisation Approval**

Statement of Compliance Verification

I hereby confirm that the instructions identified in this bulletin provide for practical and well-defined installation/inspection methods and when accomplished the product is in conformance with approved design data.

Signed, for and on behalf of Cameron Balloons Ltd.

B.E. Bower

Senior Airworthiness Engineer



Date: *05-03-2020*

Name:

Approval Statement

I hereby confirm that these instructions are in compliance with all the applicable airworthiness requirements. The technical content of this document is approved under the authority of DOA nr EASA.21J.140

Signed, for and on behalf of Cameron Balloons Ltd.

B.E. Bower

Head of Design



Date: *05-03-2020*

Name:

Cameron Balloons Ltd., St Johns Street
Bedminster, Bristol BS3 4NH, United Kingdom

Service Bulletin 28



Note: If this Service Bulletin is or will become the subject of an Airworthiness Directive, a statement to that effect must be entered in Section 10 of this form.

SB28: Accomplishment Instructions.
Stratus Double Burner; Mounting Hanger Inspection.

CBL/TN/DCB/3191

Issue: B

04/02/2020

D C Boxall



1 BACKGROUND

- 1.1.1 A Stratus Burner hanger CB8504 has failed in service after landing. The burner hanger failed, leaving one burner unit detached from the load frame. The burner was supplied in April 1999 and its history is unknown.
- 1.1.2 Investigation of the Cameron Balloons Problem Report System revealed a small number of similar failures; SB28 is issued as a result.
- 1.1.3 This document provides the accomplishment instructions for SB28.
- 1.1.4 Throughout this document all Maintenance Manual references are to Issue 10 Amendment 4 or higher.
- 1.1.5 The design of the welded hanger assembly was fundamentally revised at Issue D (2009). Only Issue A, B & C components are affected.



Fig 1. Double Stratus Burner Unit
Note failed hanger on the right.



Fig 2. Close-up of weld failure.

2 IDENTIFICATION OF AFFECTED HANGERS.

- 2.1.1 The affected hangers were fitted to double burners with serial numbers 320 or lower. The burner serial number is hand engraved onto one of the hanger end plates. Should the burner serial number be unreadable or missing Cameron Balloons can identify the burner from the manifold block serial numbers (machine engraved onto the upper surface of the burner manifold block).

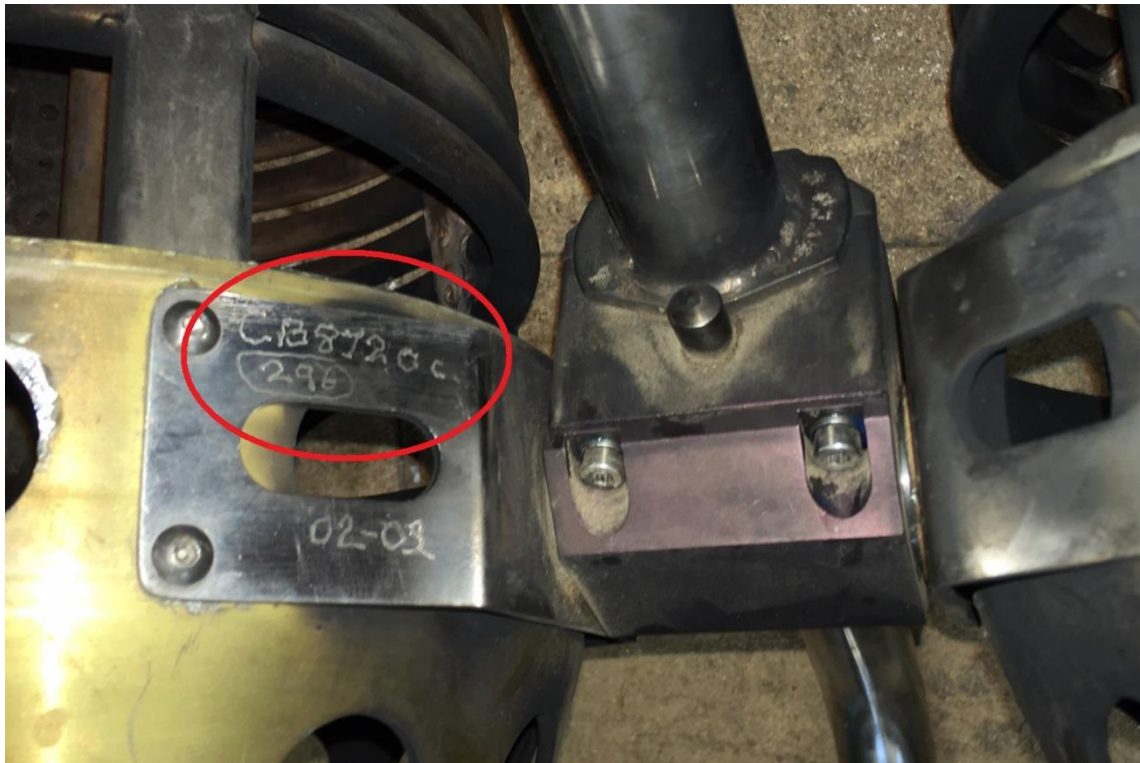

Fig 3. Burner Serial Number (296) & Part Number (CB8720) engraved on the hanger

2.1.2 Affected hangers (Issues A through C) have either no machine engraving or have “Cameron Balloons Limited” machine engraved in the upper right-hand corner of the end plate. Non-affected hangers (Issue D and E) have the text “Cameron Balloons Limited” machine engraved in the lower right-hand corner of the end plate.

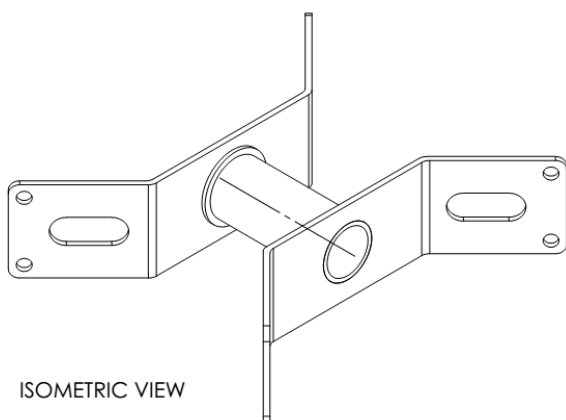

Fig 4. View of Hanger Assembly.

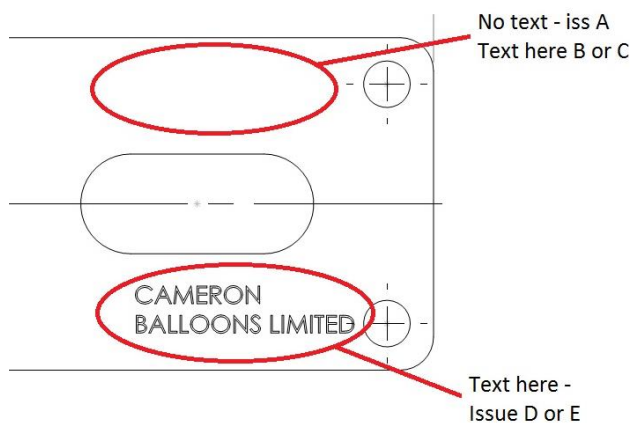

Fig 5. Position of Machine Engraving.

3 INSPECTION.

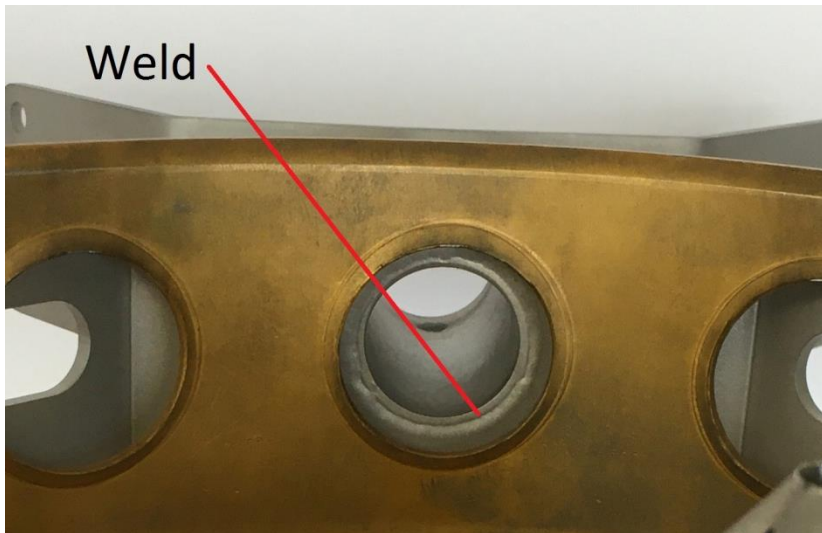

Fig 6. View of the affected weld. Note burner coil removed for clarity.

- 3.1.1 The weld in the end of the hanger can be seen through the holes in the can. A torch and a mirror may be required to give a clear view.
- 3.1.2 Remove any soot or dirt prior to inspection. WD40 or kerosene (paraffin) is the preferred cleaner; some solvent cleaners may damage the finish of the can.
- 3.1.3 Inspect the weld for any signs of cracking. Attempting to move the burner relative to the hanger may assist in making the crack visible.
- 3.1.4 If a clear view cannot be obtained or there is any doubt then the hanger must be removed from the burner. The burner is mounted to the hanger with M5 fasteners CY-0005-1004, CY-0005-1016, and CY-0005-2009. A single M3 screw secures each burner manifold block to the tubular handle.
- 3.1.5 Cracked hangers must be replaced before further flight with a new part CB-8504-0000 Issue D or later. **Cracked hangers must not be re-welded.**

4 DOCUMENTATION

- 4.1.1 Record the inspection in the aircraft log book.
- 4.1.2 Report any cracked hangers to technical@cameronballoons.co.uk including the serial number of the burner (engraved on the hanger end-plate) or the serial numbers of the manifold blocks.

5 APPROVAL

Compiled by:



D Boxall

Approved By:

